



6LY400 / 6LY440

Configuration	In-line 6-cylinder, 4-stroke, vertical, water-cooled diesel engine		
Maximum output at crankshaft	*294 kW@3300 rpm	[400 mhp]@3300 rpm	
	*324 kW@3300 rpm	[440 mhp]@3300 rpm	
Displacement	5.813 L	[354 cu in]	
Bore x stroke	106 mm x 110 mm	[4.17 in x 4.33 in]	
Combustion system	Direct Injection with Denso Common-Rail system		
Aspiration	Turbocharged with watercooled turbine housing		
Starting system	Electric starting 12V - 2.5 kW		
Alternator	12V - 125A		
Cooling system	Fresh water cooling by centrifugal fresh water pump and rubber impeller seawater pump		
Lubrication system	Enclosed, forced lubricating system		
Direction of rotation [crankshaft]	Counterclockwise viewed from stern		
Dry weight without gear	585 kg	[1290 lbs]	
Emission compliance	EU: RCD 2	IMO/GL	EMC
	US: EPA Tier 3		
Engine mounting	Rubber type flexible mounting		

NOTE:

Fuel condition: Density at 15°C = 0.842 g/cm³; 1HP = 0.7355 kW

*Fuel temperature 40°C at the inlet of the fuel injection pump [ISO 8665]

DIMENSIONS

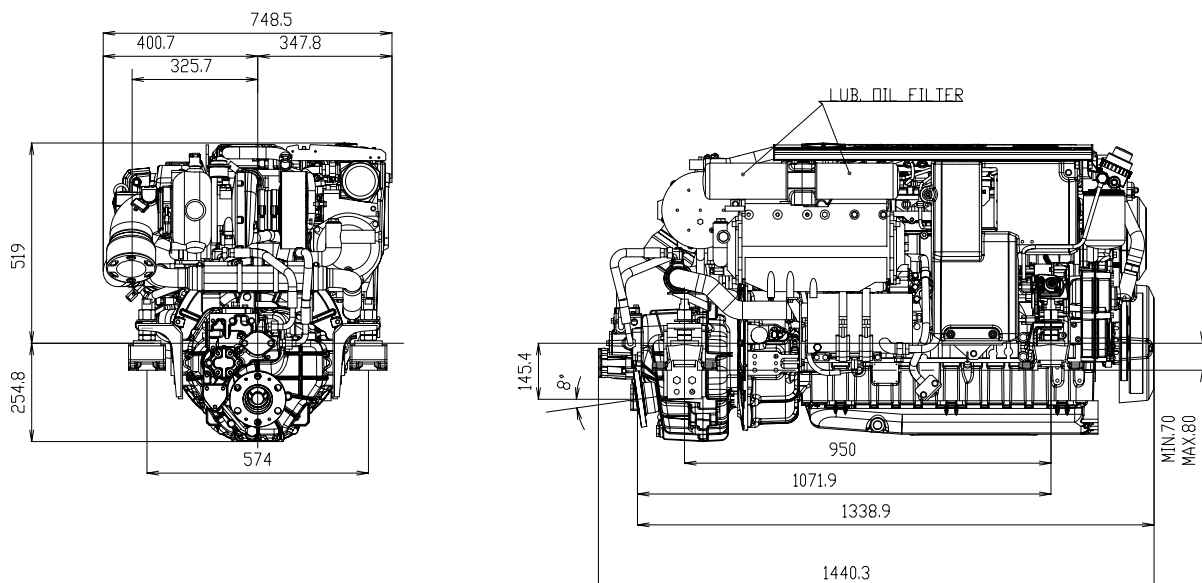

6LY440 with KMH61A2 marine gear



PERFORMANCE CURVES

6LY400

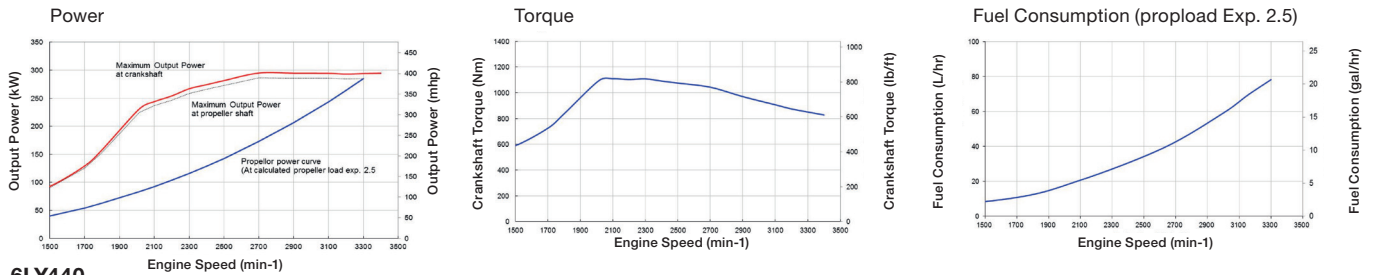

6LY440

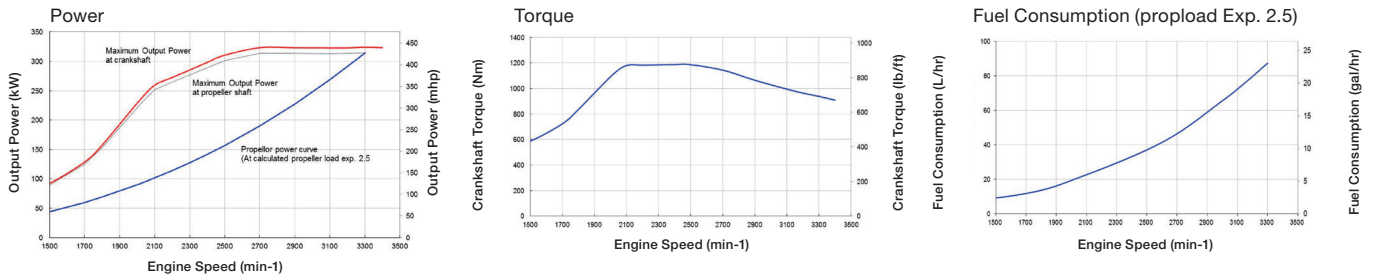

MARINE GEARS / DRIVE*

Model	KMH61A2 [down angle: 8°]			KMH61V2 [V-drive]				ZF280-1 [parallel]
Type	Hydraulically actuated multi-disc clutch			Hydraulically actuated multi-disc clutch				Hydraulically actuated multi-disc clutch
Dry weight**	81 kg [187 lbs]			113 kg [249 lbs]				113 kg [249 lbs]
Reduction ratio [fwd/asn]	1.55/1.55	2.04/2.04	2.43/2.43	1.24/1.24	1.49/1.49	1.98/1.98	2.43/2.43	Gear ratio's as available from ZF
Propeller speed [fwd/asn]	2129	1618	1358	2661	2215	1667	1358	
Direction of rotation viewed from stern	Counterclockwise & Clockwise			Counterclockwise & Clockwise				Counterclockwise & Clockwise
Dry weight engine and gear/drive**	666 kg [1468 lbs]			698 kg [1538 lbs]				698 kg [1538 lbs]

* Other marine gearboxes and configurations available upon request. Contact your local supplier for more information.
 ** Dry weight including cooler, brackets & damper disk.

ACCESSORIES

Standard engine package

- 2-pole 12V Electric system
- Exhaust/water mixing elbow [L-type]
- Alternator 12V - 125A
- Mounting brackets
- Dipstick on both sides

Optional accessories

- Flexible mounts
- Fuel water separator
- High-riser mixing elbow
- SOLAS kit including certificates
- 24V Secondary Alternator

CONTROL SYSTEM

Standard engine package

- YANMAR CAN-bus control system
- Multi-function colour display
- NMEA2000 or J1939 gauge output
- Switch panel
- Back up panel

Optional accessories

- Electronic CAN-bus control-head
- Extension wire harness
- NMEA2000 gauges
- Second or third station

NOTE: All data subject to change without notice. Text and illustrations are not binding.